

TOWER 20 AM MCW

无线室外反射式防宠物防遮盖多元被动红外探测器



安装指南

1. 简介

探测器功能

- 专利 8 个独立红外感应元阵列式处理 (Octa-PIR™)，每个感应元均具有专利真实移动识别技术(TMR)，再由中央处理器统一运算处理，可以准确识别人体移动信号或是环境树木、灌木晃动。
- 超黑晶反射式光学处理系统
- 有效减少雨雪、尘土、风、阳光直射等损毁及误报
- 拆除、移动报警
- 强 LED 指示，阳光下仍清晰可见

- 低压探测
- 全面自检
- 全天或夜晚工作模式可选。
- 下陷式探测视窗及高强度外壳
- 防喷涂及遮盖技术。
- 18 公斤级别防宠
- 垂直或左右角度调节

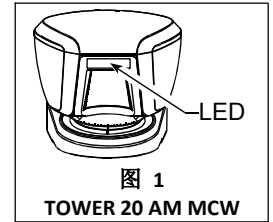

2. 技术参数

光学系统参数

探测范围: 12 米 /90°。
探测技术: 阵列式 8 独立感应元，真实移动识别处理技术
防宠级别: 18 公斤

电气参数

工作电源: 2 节 3 伏 CR 123A 锂电池
注: 只能使用以上型号电池。用过的电池处理方法遵照厂家指示。

电池寿命: 3 年 (普通使用条件)

无线参数

频率 (MHz): 315, 433, 868, 95

协议: PowerCode



图 2 - 探测区域示意图

安装类型: 墙装

安装高度: 1.5 - 3.0 米

垂直角度调节范围: 0°至 10°, 2.5° 步进。

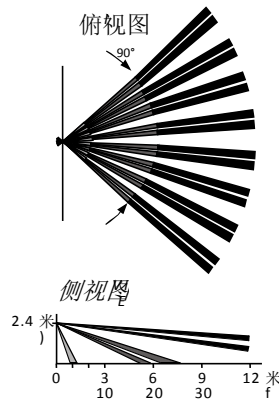
水平调节: -45° 至 +45°, 5° 步进。

环境参数:

工作温度: -35°C 至 60°C

贮存温度: -35°C 至 60°C

湿度: 95% 最大。

抗白光干扰: > 6500 lux

物理参数:

尺寸 (高 x 长 x 宽): 157x147x124mm

重量: 600 克

颜色: 白或灰

标准:

符合: EN 50131-2-2 3 级 环境部分 IV 章节. IP 55.等级

EMI: CE 和 EN 50131 (最小 . 20 V/m 10 到 1000 MHz, 最小 . 10 V/m 1GHz 至 2GHz).

US 专利号: 7250605, 6818881, 5693943

安装

3. 安装步骤

3.1 DIP 拨码开关设置

打开探测器下部的两层底盖 (见图 3, 4-8 步) 可见到 DIP 拨码开关。根据表 1 设置各拨码开关:

表 1 - DIP 开关设置

DIP 编号 #	功能	描述	默认值
1	LED 灯开关 OFF/ON	关/OFF: 探测到人体移动或遮盖信号时指示灯不亮, 但可通过 TST 端子使指示灯启动。 开/ON: 探测到人体移动或遮盖信号时 LED 灯亮/ON.	亮/ON
2	探测功能全天或夜间工作模式 24H / night only	关/OFF: 探测功能全天有效 开/ON: 探测功能夜晚才启动.	关/OFF
3	防遮盖功能打开或关闭 AM ON / OFF	开/ON: 防遮盖功能有效 关/OFF: 防遮盖功能无效 从 OFF 拨到 ON 会重启 60 秒自检	开/ON
4	备用/TBD		

3.2 安装电池 (图 3)

推荐在办公桌上安装好电池。安装电池后, LED 灯会闪烁 30 秒, 然后进入 15 分钟的步行测试模式。

3.3 注册

按照控制系统 (主机) 安装说明书中的注册操作部分, 将该探测器注册到系统中。当系统提示发射信号时, 可通过触发防拆开关或重新安装电池来触发信号。

D-301524

3.4 安装

A 支架安装 (见图 4) - 将支架固定在稳定的墙面或台柱上。支架应与探测区域尽可能平行。

B 范围及角度调节 (见图 5) 根据所需探测范围及高度, 调节探测器垂直及水平角度 (见图 4, 1-6 步), 然后盖好探测器。注意防拆开关 (见图 4, 7-10. 步)

表 2 是探测器不同安装高度和探测范围内的垂直刻度调节位置。但调节后必须进行全面的、多次的步行测试以确定调节效果。

C 固定 将探测器固定在支架上 (见图 4-4 步)。

表 2 - 垂直刻度调节

安装高度 (米)	探测距离 (米)					
	2m	4m	6m	8m	10m	12m
3.0m	-	1	2	2	3	3
2.5m	1	1	2	3	4	4
2.0m	1	2	3	4	5	5
1.5m	2	3	4	5	-	-

3.5 测试

3.6 测试

- A. 打开步行测试模式（见图 3，1 至 3）：打开探测器底盖，然后再盖上，LED 灯会持续闪烁 30 秒，然后会进入 15 分钟的步行测试状态。
- B. 从期望的防护距离走近探测区域，确认是每次探测器均可正常探测到，指示灯亮 2 秒，报警主机正常报警。如有必要，则调整探测器垂直或水平角度。
- 重要提示：** 需告知用户每周至少步行测试一次，以保证探测器工作正常。
- C. 在探测器前放一纸板以检测防遮挡功能。2 分钟后 LED 长亮，主机收到防遮挡信号则说明探测器防遮挡功能正常。
- D. 移开纸板，约 30 秒后探测器 LED 灯应熄灭。

表 3-LED 指示

事件/状态		显示
电池安装后 30 秒内		慢闪
探测到遮盖		快闪 5 秒
报警	测试模式下	亮 2 秒（15 分钟内）
	工作模式下	亮 2 秒

在工作模式下报警一次后，探测器会进入动态检测休眠状态，直至连续的 2 分钟内未探测到移动信号后才会进入下一次触发前的预备工作状态，如探测至移动信号即触发。

3.6 安装底盖，结束安装 (图 5, 见 7-10)



图3 安装电池



图4 安装支架及探测器

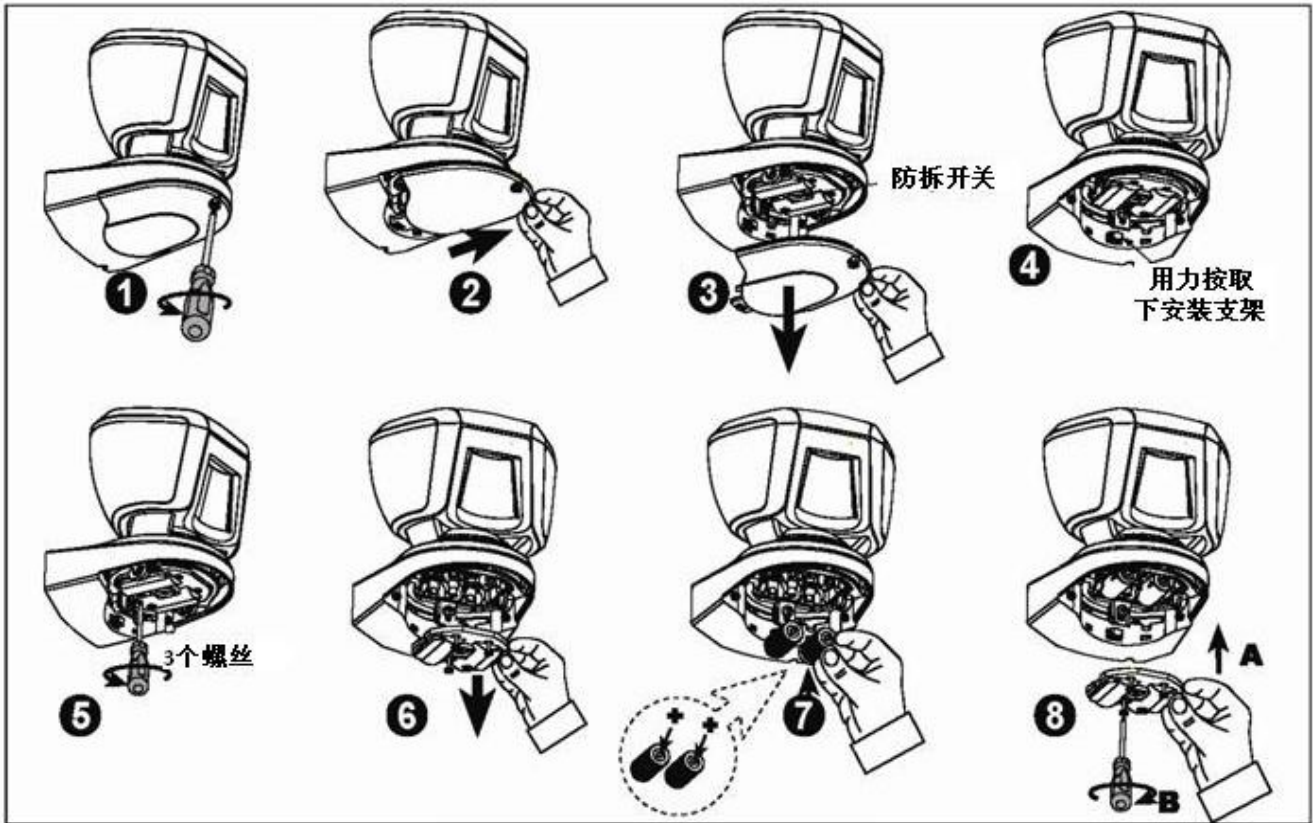

图5 距离调节、安装角度调节

WARRANTY

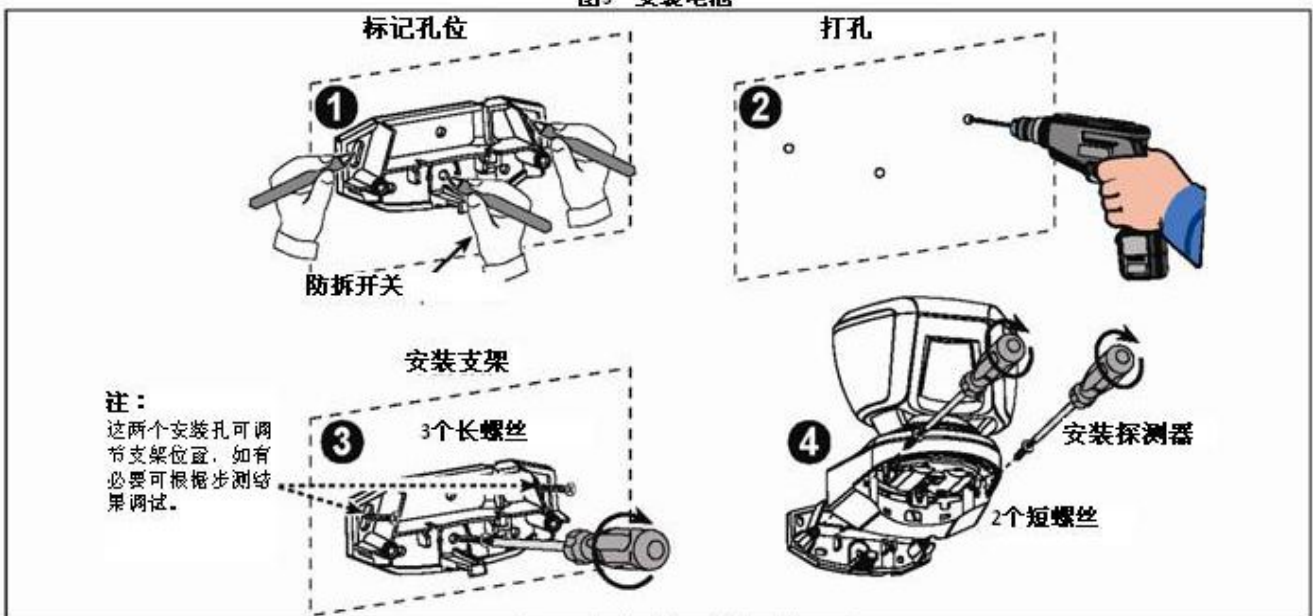
Visonic Limited (the "Manufacturer") warrants this product only (the "Product") to the original purchaser only (the "Purchaser") against defective workmanship and materials under normal use of the Product for a period of twelve (12) months from the date of shipment by the Manufacturer.

This Warranty is absolutely conditional upon the Product having been properly installed, maintained and operated under conditions of normal use in accordance with the Manufacturers recommended installation and operation instructions. Products which have become defective for any other reason, according to the Manufacturers discretion, such as improper installation, failure to follow recommended installation and operational instructions, neglect, willful damage, misuse or vandalism, accidental damage, alteration or tampering, or repair by anyone other than the manufacturer, are not covered by this Warranty.

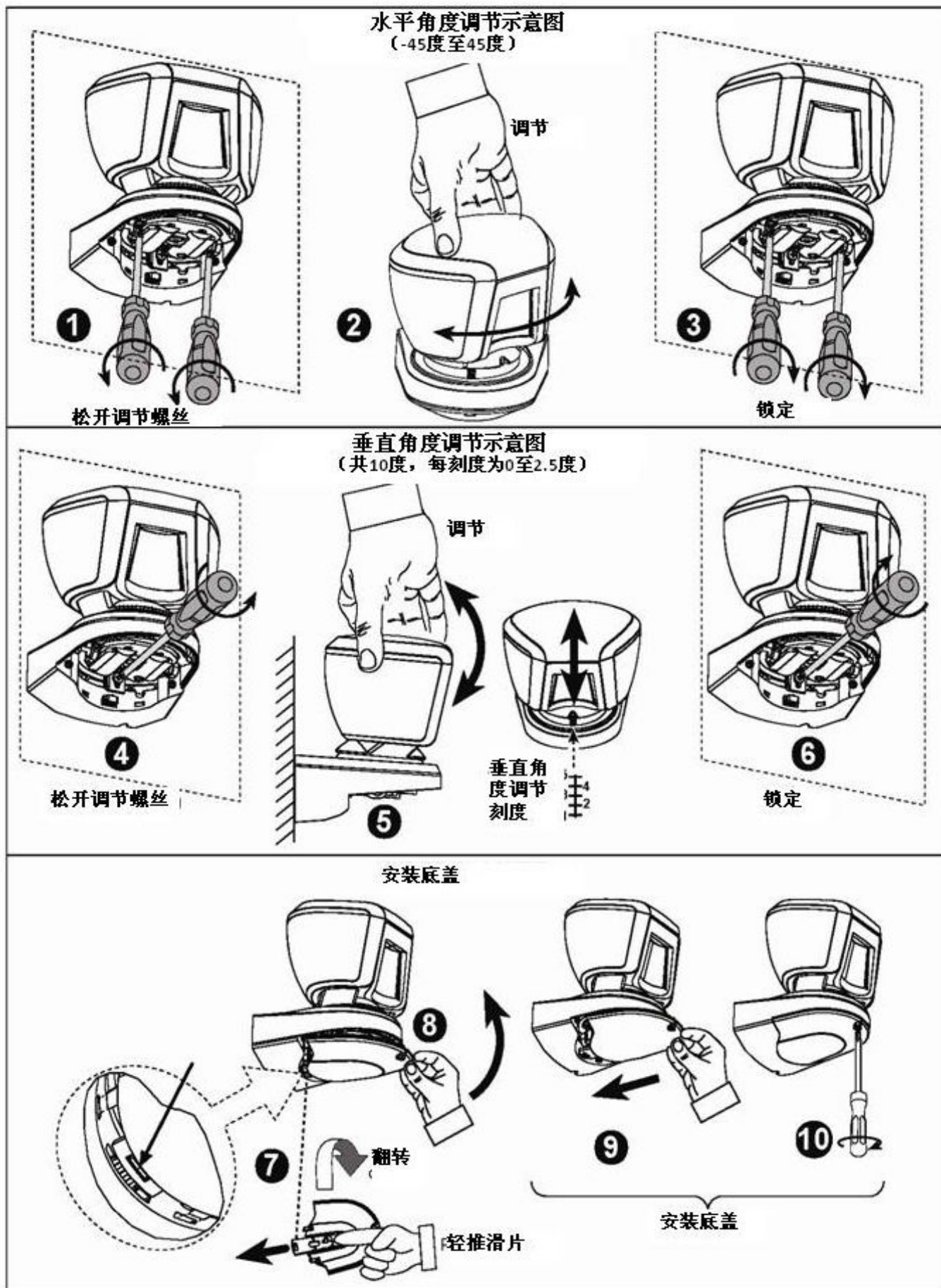
The Manufacturer does not represent that this Product may not be compromised and/or circumvented or that the Product will prevent any death and/or personal injury and/or damage to property resulting from burglary, robbery, fire or otherwise, or that the Product will in all cases provide adequate warning or protection. The Product, properly installed and maintained, only reduces the risk of such events without warning and it is not a guarantee or insurance that such events will not occur.

THIS WARRANTY IS EXCLUSIVE AND EXPRESSLY IN LIEU OF ALL OTHER WARRANTIES, OBLIGATIONS OR LIABILITIES, WHETHER WRITTEN, ORAL, EXPRESS OR IMPLIED, INCLUDING ANY WARRANTY OF MERCHANTABILITY OR FITNESS FOR A PARTICULAR PURPOSE, OR OTHERWISE. IN NO CASE SHALL THE MANUFACTURER BE LIABLE TO ANYONE FOR ANY CONSEQUENTIAL OR INCIDENTAL DAMAGES FOR BREACH OF THIS WARRANTY OR ANY OTHER WARRANTIES WHATSOEVER, AS AFORESAID.

THE MANUFACTURER SHALL IN NO EVENT BE LIABLE FOR ANY SPECIAL, INDIRECT, INCIDENTAL, CONSEQUENTIAL OR PUNITIVE DAMAGES OR FOR LOSS, DAMAGE, OR EXPENSE, INCLUDING LOSS OF USE, PROFITS, REVENUE, OR GOODWILL, DIRECTLY OR INDIRECTLY ARISING FROM PURCHASER'S USE OR INABILITY TO USE THE PRODUCT, OR FOR LOSS OR DESTRUCTION OF OTHER PROPERTY OR FROM ANY OTHER CAUSE, EVEN IF MANUFACTURER HAS BEEN ADVISED OF THE POSSIBILITY OF SUCH DAMAGE.

THE MANUFACTURER SHALL HAVE NO LIABILITY FOR ANY DEATH, PERSONAL AND/OR BODILY INJURY AND/OR DAMAGE TO PROPERTY OR OTHER LOSS WHETHER DIRECT, INDIRECT, INCIDENTAL, CONSEQUENTIAL OR OTHERWISE, BASED ON A CLAIM THAT THE PRODUCT FAILED TO FUNCTION.

However, if the Manufacturer is held liable, whether directly or indirectly, for any loss or damage arising under this limited warranty, **THE MANUFACTURER'S MAXIMUM LIABILITY (IF ANY) SHALL NOT IN ANY CASE EXCEED THE PURCHASE PRICE OF THE PRODUCT**, which shall be fixed as liquidated damages and not as a penalty, and shall be the complete and exclusive remedy against the Manufacturer.

When accepting the delivery of the Product, the Purchaser agrees to the said conditions of sale and warranty and he recognizes having been informed of.

Some jurisdictions do not allow the exclusion or limitation of incidental or consequential damages, so these limitations may not apply under certain circumstances.

The Manufacturer shall be under no liability whatsoever arising out of the corruption and/or malfunctioning of any telecommunication or electronic equipment or any programs.

The Manufacturers obligations under this Warranty are limited solely to repair and/or replace at the Manufacturer's discretion any Product or part thereof that may prove defective. Any repair and/or replacement shall not extend the original Warranty period. The Manufacturer shall not be responsible for dismantling and/or reinstallation costs. To exercise this Warranty the Product must be returned to the Manufacturer freight pre-paid and insured.

All freight and insurance costs are the responsibility of the Purchaser and are not included in this Warranty. This warranty shall not be modified, varied or extended, and the Manufacturer does not authorize any person to act on its behalf in the modification, variation or extension of this warranty. This warranty shall apply to the Product only. All products, accessories or attachments of others used in conjunction with the Product, including batteries, shall be covered solely by their own warranty, if any. The Manufacturer shall not be liable for any damage or loss whatsoever, whether directly, indirectly, incidentally, consequentially or otherwise, caused by the malfunction of the Product due to products, accessories, or attachments of others, including batteries, used in conjunction with the Products. This Warranty is exclusive to the original Purchaser and is not assignable.

This Warranty is in addition to and does not affect your legal rights. Any provision in this warranty which is contrary to the Law in the state or country where the Product is supplied shall not apply.

Warning: The user must follow the Manufacturer's installation and operational instructions including testing the Product and its whole system at least once a week and to take all necessary precautions for his/her safety and the protection of his/her property.

1/08



W.E.E.E. Product Recycling Declaration

For information regarding the recycling of this product you must contact the company from which you originally purchased it. If you are discarding this product and not returning it for repair then you must ensure that it is returned as identified by your supplier. **This product is not to be thrown away with everyday waste.**
Directive 2002/96/EC Waste Electrical and Electronic Equipment.



Visonic®

VISONIC LTD. (ISRAEL): P.O.B 22020 TEL-AVIV 61220 ISRAEL. PHONE: (972-3) 645-6789, FAX: (972-3) 645-6788

VISONIC INC. (U.S.A.): 65 WEST DUDLEY TOWN ROAD, BLOOMFIELD CT. 06002-1376. PHONE: (860) 243-0833, (800) 223-0020. FAX: (860) 242-8094

VISONIC LTD. (UK): UNIT 6 MADINGLEY COURT CHIPPENHAM DRIVE KINGSTON MILTON KEYNES MK10 0BZ. TEL: (0870) 7300800 FAX: (0870) 7300801

PRODUCT SUPPORT: (0870) 7300830

VISONIC GmbH (D-A-CH): KIRCHFELDSTR. 118, D-40215 DÜSSELDORF, TEL.: +49 (0)211 600696-0, FAX: +49 (0)211 600696-19

VISONIC IBERICA: ISLA DE PALMA, 32 NAVE 7, POLÍGONO INDUSTRIAL NORTE, 28700 SAN SEBASTIÁN DE LOS REYES, (MADRID), ESPAÑA. TEL (34)

91659-3120, FAX (34) 91663-8468. www.visonic-iberica.es

INTERNET: www.visonic.com

©VISONIC LTD. 2009 TOWER 20 AM D-301524 **Preparation for REV. 0, 9/09**



MADE IN
ISRAEL